

Section 6 - Storage

Table of Contents

Cold Weather or Extended Storage.....	74	Air-Actuated Single-Point Drain System.....	77
Preparing Power Package for Storage.....	74	Boat in the Water	77
Engine and Fuel System Preparation	75	Boat out of the Water	79
Draining the Seawater System.....	76	Three-Point Manual Drain System.....	81
Drain System Identification.....	76	Boat in the Water	81
Air Actuated Single Point Drain System		Boat out of the Water	82
.....	76	Battery Storage.....	83
Three Point Manual Drain System	77	Power Package Recommissioning.....	83

Cold Weather or Extended Storage

IMPORTANT: Mercury MerCruiser strongly recommends that this service should be performed by an authorized Mercury MerCruiser dealer. Damage caused by freezing temperatures IS NOT covered by the Mercury MerCruiser Limited Warranty.

NOTICE

Water trapped in the seawater section of the cooling system can cause corrosion or freeze damage. Drain the seawater section of the cooling system immediately after operation or before any length of storage in cold weather. If the boat is in the water, keep the seacock closed until restarting the engine to prevent water from flowing back into the cooling system. If the boat is not fitted with a seacock, leave the water inlet hose disconnected and plugged.

NOTE: As a precautionary measure, attach a tag to the key switch or steering wheel of the boat reminding the operator to open the seacock or unplug and reconnect the water inlet hose before starting the engine.

IMPORTANT: Mercury MerCruiser requires that propylene glycol antifreeze, mixed to the manufacturers instructions, be used in the seawater section of the cooling system for freezing temperatures or extended storage. Make sure that the propylene glycol antifreeze contains a rust inhibitor and is recommended for use in marine engines. Be certain to follow the propylene glycol manufacturer's recommendations.

Preparing Power Package for Storage

1. Fill the fuel tanks with fresh gasoline (that does not contain alcohol) and a sufficient amount of Quicksilver Gasoline Stabilizer for Marine Engines to treat the gasoline. Follow instructions on the container.
2. If the boat is to be placed in storage with fuel containing alcohol in fuel tanks (if fuel without alcohol is not available): Fuel tanks should be drained as low as possible and Mercury/Quicksilver Gasoline Stabilizer for Marine Engines added to any fuel remaining in the tank. Refer to **Fuel Requirements** for additional information.
3. Flush the cooling system. Refer to the **Maintenance** section.
4. Supply cooling water to engine. Refer to the **Maintenance** section
5. Operate the engine sufficiently to bring it up to normal operating temperature and allow fuel with Mercury/Quicksilver Gasoline Stabilizer to circulate through the fuel system. Shut off the engine.
6. Change the oil and oil filter.
7. Prepare the engine and fuel system for storage. See **Engine and Fuel System Preparation**.
8. Drain the engine seawater cooling system. See **Draining the Seawater System**.

NOTICE

Water trapped in the seawater section of the cooling system can cause corrosion or freeze damage. Drain the seawater section of the cooling system immediately after operation or before any length of storage in cold weather. If the boat is in the water, keep the seacock closed until restarting the engine to prevent water from flowing back into the cooling system. If the boat is not fitted with a seacock, leave the water inlet hose disconnected and plugged.

9. For additional assurance against freezing and rust, after draining, fill the seawater cooling system with propylene glycol mixed to the manufacturer's recommendation to protect engine to the lowest temperature to which it will be exposed during freezing temperatures or extended storage.
10. Store the battery according to the manufacturer's instructions.

ENGINE AND FUEL SYSTEM PREPARATION

⚠ WARNING

Fuel is flammable and explosive. Ensure the key switch is off and the lanyard is positioned so that the engine cannot start. Do not smoke or allow sources of spark or open flame in the area while servicing. Keep the work area well ventilated and avoid prolonged exposure to vapors. Always check for leaks before attempting to start the engine and wipe up any spilled fuel immediately.



⚠ WARNING

Fuel vapors trapped in the engine compartment may be an irritant, cause difficulty breathing, or may ignite resulting in a fire or explosion. Always ventilate the engine compartment before servicing the power package.

NOTICE

Running out of fuel can damage catalyst components. Do not allow the fuel tanks to become empty during operation.

1. In a 23 liter (6 US gal.) remote fuel tank mix:
 - a. 19 liter (5 US gal.) regular unleaded 87 octane (90 RON) gasoline
 - b. 1.89 liter (2 US qt.) Premium Plus 2-Cycle TC-W3 Outboard Oil
 - c. 150 ml (5 oz) Fuel System Treatment and Stabilizer or 30 ml (1 oz) Fuel System Treatment and Stabilizer Concentrate

Tube Ref No.	Description	Where Used	Part No.
 115	Premium Plus 2-cycle TC-W3 Outboard Oil	Fuel system	92-858026K01
 124	Fuel System Treatment & Stabilizer	Fuel system	858071K01

2. Allow the engine to cool.

IMPORTANT: Immediately wipe up any fuel spills or sprays.

3. Close the fuel shut off valve, if equipped. Disconnect and plug the fuel inlet fitting if not equipped with a fuel shut off valve.
4. Connect the remote fuel tank (with the fogging mixture) to the fuel inlet fitting.

IMPORTANT: Supply cooling water to the engine.

5. Start and operate the engine at 1300 RPM for five minutes.
6. After the specified operating time is complete, slowly return the throttle to idle and shut the engine off.

IMPORTANT: Ensure that some fogging mixture remains in the engine. Do not allow the engine's fuel system to become completely dry.

7. Replace the water separating fuel filter element. Refer to **Section 5**.

Draining the Seawater System

CAUTION

Water can enter the bilge when the drain system is open, damaging the engine or causing the boat to sink. Remove the boat from the water or close the seacock, disconnect and plug the seawater inlet hose, and ensure the bilge pump is operational before draining. Do not operate the engine with the drain system open.

IMPORTANT: Only drain the seawater section of the closed-cooling system.

IMPORTANT: The boat must be as level as possible to ensure complete draining of the cooling system.

Your power package is equipped with a drain system. Refer to **Drain System Identification** to determine which instructions apply to your power package.

IMPORTANT: The engine must not be operating at any point during the draining procedure.

IMPORTANT: Mercury MerCruiser requires that propylene glycol antifreeze, mixed to the manufacturer's instructions, be used in the seawater section of the cooling system for freezing temperatures or extended storage. Make sure that the propylene glycol antifreeze contains a rust inhibitor and is recommended for use in marine engines. Be certain to follow the propylene glycol manufacturer's recommendations.

Drain System Identification

NOTE: All drain plugs are fitted with blue wing nuts.

AIR ACTUATED SINGLE POINT DRAIN SYSTEM

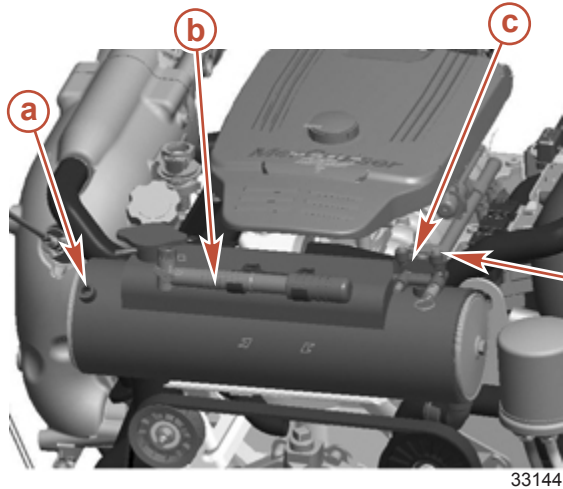

Closed-cooled models

- a - Blue drain plug location
- b - Blue air pump

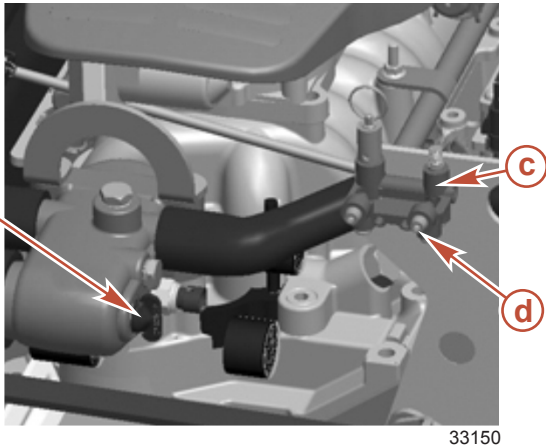

Seawater-cooled models

- c - Air manifold
- d - Green indicators

THREE POINT MANUAL DRAIN SYSTEM

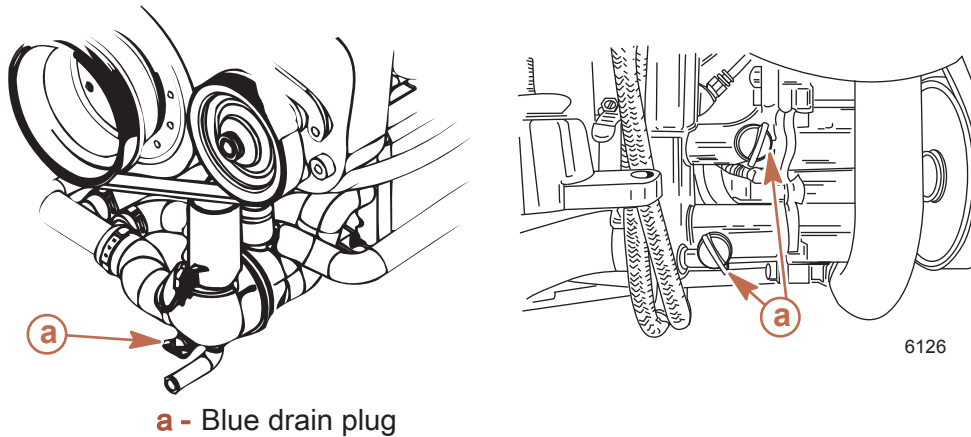

Air-Actuated Single-Point Drain System BOAT IN THE WATER

NOTE: This procedure is written for the blue air pump that is attached to the engine. However, any air source can be used.

1. Close the seacock (if equipped) or remove and plug the water inlet hose.
2. Remove the blue air pump from the engine.
3. Ensure that the lever on top of the pump is flush with the handle (horizontal).
4. Install the air pump on the actuator fitting.
5. Pull lever on air pump (vertical) to lock pump on the fitting.

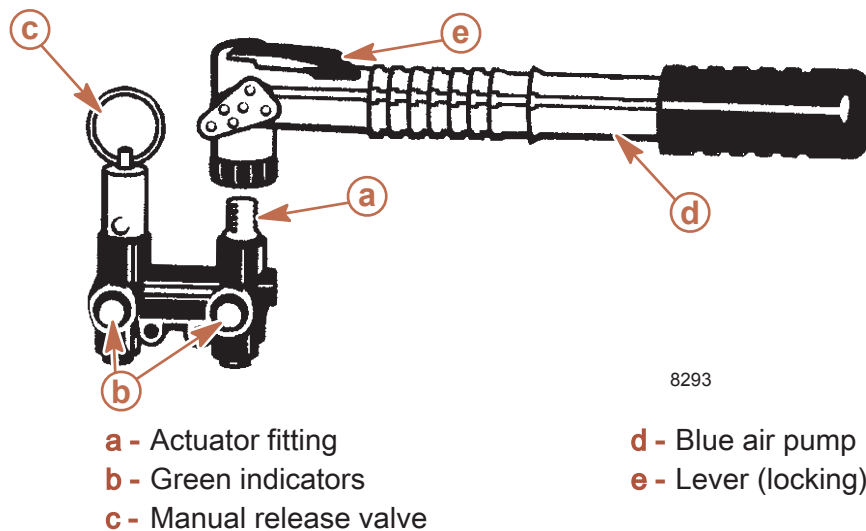

6. Pump air into the system until both green indicators extend and water drains from both sides of the engine. The port side will begin draining before the starboard side.

7. Immediately remove the blue drain plug from the side of the thermostat housing or the heat exchanger. This must be removed within 30 seconds to properly vent the cooling system.

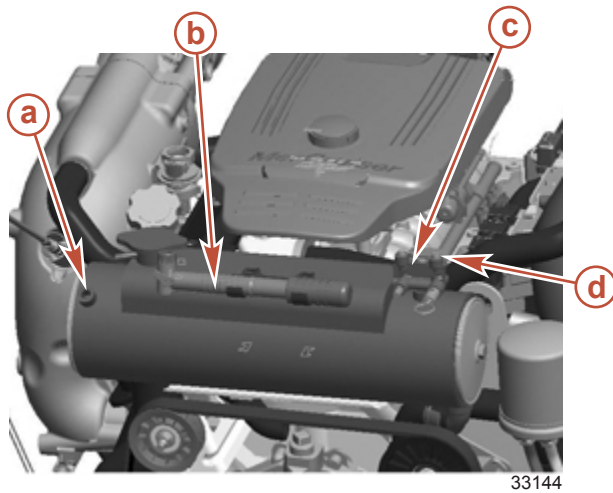

Closed Cooled Models

- a - Blue drain plug location
- b - Blue air pump

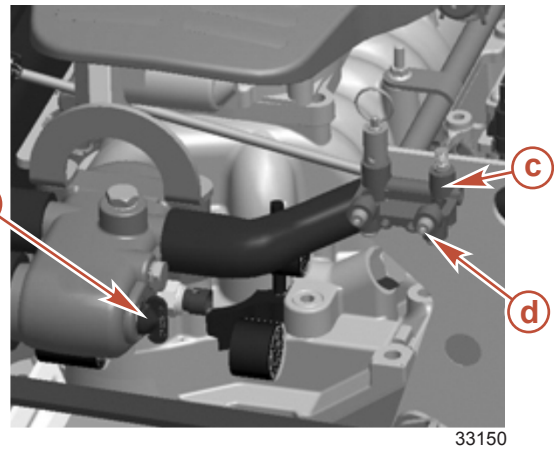

Seawater Cooled Models

- c - Air manifold
- d - Green indicators

8. Verify that water is draining from each opening. If not, use the **Three Point Manual Drain System** instructions.

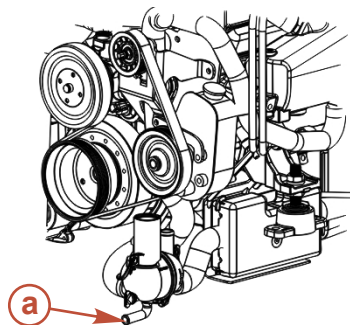

a - Port side drain location

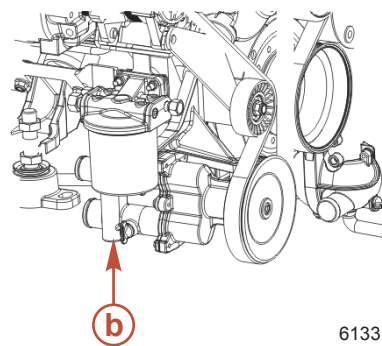

b - Starboard side drain location

9. Allow the system to drain for a minimum of five minutes. Pump air as necessary to keep the green indicators extended.
10. Crank the engine over slightly with the starter motor to purge any water trapped in the seawater pump. Do not allow engine to start.
11. Reinstall the blue drain plug in the thermostat housing or heat exchanger.
12. Remove the blue air pump from the air manifold and return it to the mounting bracket.
13. Mercury MerCruiser recommends leaving the drain system open while transporting the boat or while performing other maintenance. This helps ensure that all water is drained.

- Before launching the boat, pull up on the manual release valve. Verify that the green indicators are no longer extended.

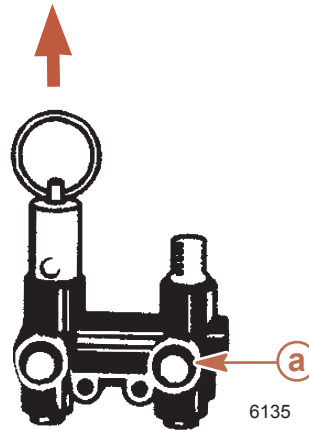

a - Green indicators

- Open the seacock, if equipped, or unplug and reconnect the water inlet hose prior to operating the engine.

BOAT OUT OF THE WATER

NOTE: This procedure is written for the blue air pump that is attached to the engine. However, any air source can be used.

- Place the boat on a level surface to ensure complete draining of system.
- Remove the blue air pump from the engine.
- Ensure that the lever on top of the pump is flush with the handle (horizontal).
- Install the air pump on the actuator fitting.
- Pull lever on air pump (vertical) to lock pump on the fitting.

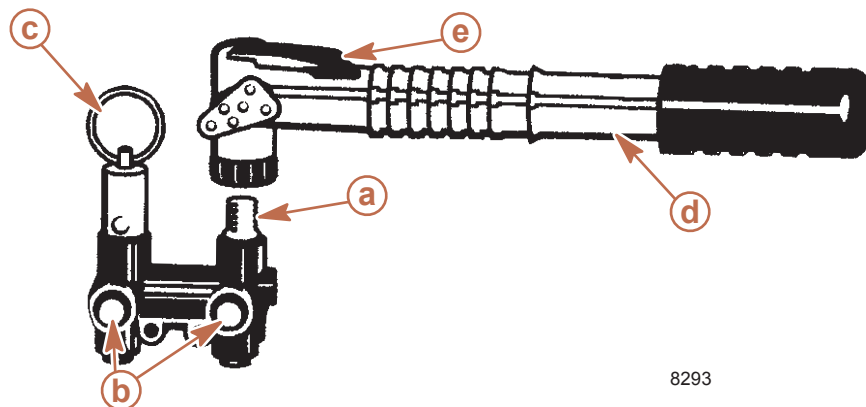

a - Actuator fitting
b - Green indicators
c - Manual release valve

d - Air pump
e - Lever (locking)

- Pump air into the system until both green indicators extend and water drains from both sides of the engine. The port side will begin draining before the starboard side.

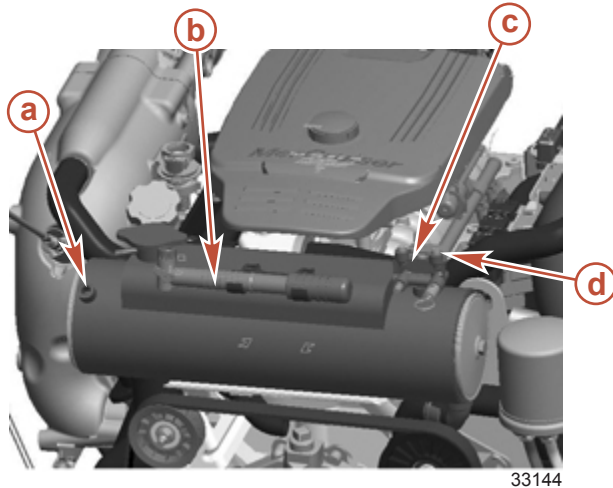

Closed Cooled Models

- a - Blue drain plug location
- b - Blue air pump

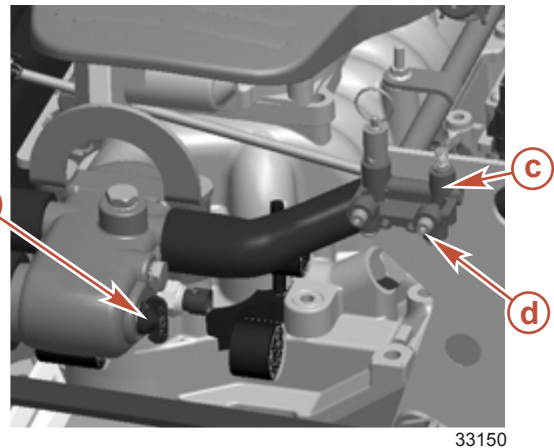

Seawater Cooled Models

- c - Air manifold
- d - Green indicators

- Verify that water is draining from each opening. If not, use the **Three Point Manual Drain System** instructions.

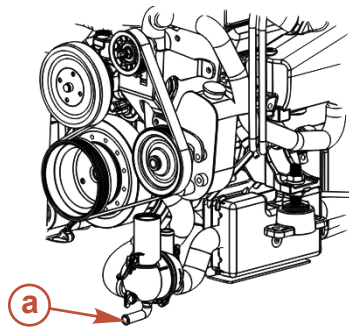

a - Port side drain location

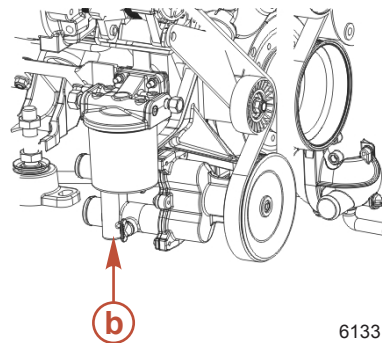

b - Starboard side drain location

- Allow the system to drain for a minimum of five minutes. Pump air as necessary to keep the green indicators extended.
- Crank the engine over slightly with starter motor to purge any water trapped in the seawater pump. Do not allow engine to start.
- Remove the air pump from the air manifold and return it to the mounting bracket.
- Mercury MerCruiser recommends leaving the drain system open while transporting the boat or while performing other maintenance. This helps ensure that all water is drained.

12. Before launching the boat, pull up on the manual release valve. Verify that the green indicators are no longer extended.

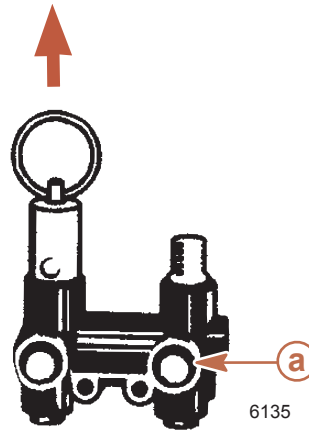

a - Green indicators

Three-Point Manual Drain System

BOAT IN THE WATER

NOTE: Use this procedure if your engine is not equipped with an air-actuated single-point drain system or if the air-actuated single point drain system fails.

1. Close the seacock (if equipped) or remove and plug the water inlet hose.
2. Remove the blue drain plug from the distribution housing (lower front, port side).

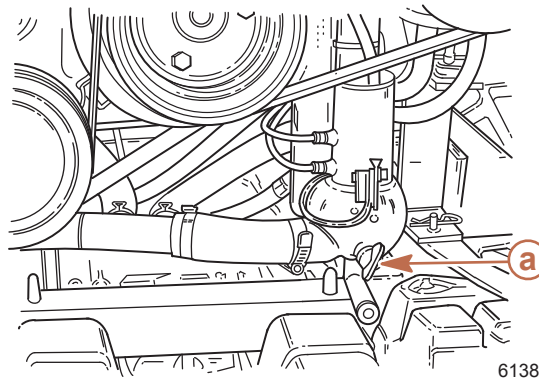

a - Blue drain plug

3. To properly vent the cooling system, remove the blue drain plug from the side of the thermostat housing within 30 seconds.

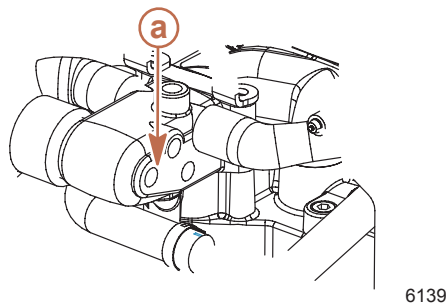

a - Blue drain plug location

4. Remove the two blue drain plugs from the seawater pickup pump (front, starboard side).

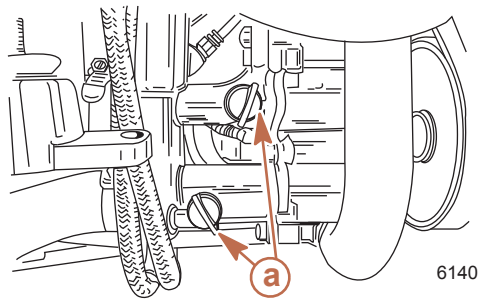

a - Blue drain plugs

5. Verify that water is draining from each opening.
6. Allow the system to drain for a minimum of five minutes. We recommend leaving the drain system open while transporting the boat or performing other maintenance to ensure that all water is drained.
7. Crank the engine over slightly with starter motor to purge any water trapped in the seawater pickup pump. Do not allow the engine to start.
8. Before launching the boat or starting the engine, close the drain system by installing the four blue drain plugs.
9. Open the seacock, if equipped, or unplug and reconnect the water inlet hose prior to operating the engine.

BOAT OUT OF THE WATER

NOTE: Use this procedure if your engine is not equipped with an air-actuated single-point drain system or if the single-point drain system fails.

1. Place the boat on a level surface to ensure complete draining of the system.
2. Remove three blue drain plugs: one from the distribution housing (lower front, port side) and two from the seawater pickup pump (front, starboard side).

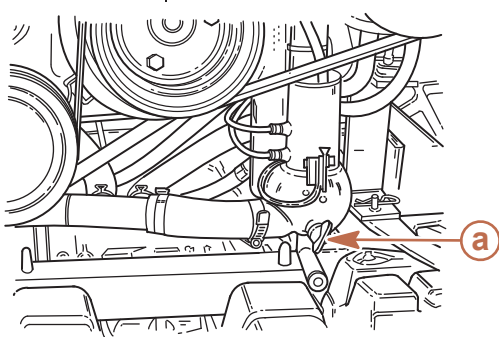

a - Blue drain plug

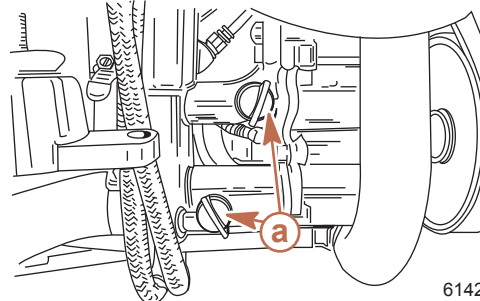

3. Verify that water is draining from each opening.
4. Allow the system to drain for a minimum of five minutes. We recommend leaving the drain system open while transporting the boat or performing other maintenance to ensure that all water is drained.
5. Crank the engine over slightly with starter motor to purge any water trapped in the seawater pickup pump. Do not allow the engine to start.
6. Before launching the boat or starting the engine, close the drain system by installing the three blue drain plugs.

Battery Storage

Whenever the battery will be stored for an extended period of time, be sure the cells are full of water and the battery is fully charged and in good operating condition. It should be clean and free of leaks. Follow the battery manufacturer's instructions for storage.

Power Package Recommissioning

1. Ensure that all cooling system hoses are connected properly and hose clamps are tight.

⚠ CAUTION

Disconnecting or connecting the battery cables in the incorrect order can cause injury from electrical shock or can damage the electrical system. Always disconnect the negative (-) battery cable first and connect it last.

2. Install a fully charged battery. Clean the battery cable clamps and terminals and reconnect cables. Tighten each cable clamp securely when connecting.
3. Coat the terminal connections with a battery terminal anti-corrosion agent.
4. Perform all the checks in the before starting column of the **Operation Chart**.

NOTICE

Without sufficient cooling water, the engine, the water pump, and other components will overheat and suffer damage. Provide a sufficient supply of water to the water inlets during operation.

5. Start the engine and closely observe instrumentation to ensure that all systems are functioning correctly.
6. Carefully inspect the engine for fuel, oil, fluid, water and exhaust leaks.
7. Inspect the steering system, shift and throttle control for proper operation.

Notes: