

**COMPARE FOR YOURSELF**



**MERCURY® MERCRUISER:**  
*“Highest in Customer Satisfaction with Sterndrive Engines, Two Years in a Row”*

**MERCRUISER® IS EASIER TO USE AND MAINTAIN.**



Every MerCruiser inboard, sterndrive and tow sports model, even our carbureted models, is equipped with **TURN-KEY STARTING** for instant, effortless starts even in cold weather.

MerCruiser Volvo Penta



**EASY OIL DRAIN SYSTEM** makes changing the oil in your boat easier than changing the oil in your car.



**EASY WATER DRAIN SYSTEM** lets you extend your boating season, early and late, without worrying about freeze damage. In addition, the all-new Vazer™ sterndrive is self-draining.



**MERCRUISER EASY-ACCESS DRIVE LUBE MONITOR** allows drive lubricant to be visually checked and refilled from **inside** the boat.



**PERMALUBE® U-JOINTS** are sealed and never require further lubrication.



**EASY-MAINTENANCE DRIVE COUPLER** can be lubricated from inside the boat without removing the drive.



**LARGEST SERVICE NETWORK.** With more than 4000 dealers nationwide, MerCruiser has more servicing locations and trained technicians.



**MERCRUISER IS LESS EXPENSIVE TO OWN AND OPERATE.**



MerCruiser gas-powered models are designed to run best on regular 87-octane gasoline instead of more costly premium-grade fuels.



MerCruiser designs its products to require as little maintenance as possible. Our recommended maintenance intervals are every 100 hours versus 50 hours for Volvo Penta®



**MERCRUISER IS BUILT TO LAST.**



**THREE-YEAR LIMITED CORROSION FAILURE WARRANTY.** Every MerCruiser model comes with the industry's only three-year corrosion failure warranty. Plus, SeaCore™ features an additional year for four years of corrosion protection.



**MERCATHODE® CORROSION PROTECTION SYSTEM** actively combats corrosion on underwater parts. Standard on all Bravo® drives and available as a kit on Alpha® drives.



**MORE PROTECTIVE ANODES.** In addition to our full array of anodes, all Bravo Three® drives feature the extra protection of additional anodes on the anticavitation plate and propshaft.



**HIGHEST-QUALITY MATERIALS.** MerCruiser-exclusive XK-360 aluminum alloy and 316 stainless steel underwater hardware provide maximum durability in corrosive environments. Our Tri-Paint coating process uses Irridite, Electro-Deposition Primer and Phantom Black Powder Paint topcoat to ensure long life in harsh marine use.



**MERCRUISER DELIVERS THERE AND BACK RELIABILITY.**



**ENGINE GUARDIAN.** Engine Guardian on SmartCraft® models constantly monitors engine operation and not only alerts you of an engine problem but also reduces power to a safe level that allows you to continue operating without engine damage.



**FLO-TORQ® II PROP HUB.** The unique design of this hub helps prevent damage to your drive unit by absorbing shock from propeller impact with an underwater object. The Flo-Torq II hub is designed to be boater serviceable, so you can get back to your weekend quickly with a simple replacement, if necessary.



**POWER TRIM XD CYLINDERS.** Power Trim XD cylinders feature our exclusive hydraulic memory system that returns your drive to its original trim position if it impacts an underwater obstacle, allowing you to maintain full steering control.



# MERCUISER DRIVES. A HISTORY OF INNOVATION.

Mercury MerCruiser® has a long history of developing industry-leading sterndrive and inboard technologies. We continue to evolve our lineup with refinements that make our sterndrives perform better and last longer.



**ALPHA DRIVES.** With their revised engine-management programming, Alpha drives deliver smoother and easier shifts. Ideal for everything from runabouts to pontoons and small cruisers, the Alpha drive is simple, solid, versatile and fast. Exclusive maintenance-free features like Permalube U-joints eliminate the need for periodic lubrication, and user-friendly features like an engine-mounted Drive Lube Monitor and Audio Warning System add peace of mind and convenience.



**BRAVO DRIVES.** Our latest Bravo drives feature best-in-class shifting, better by as much as 85 percent when compared to previous models. The Bravo lineup features the popular twin-propeller Bravo Three and the heavy duty Bravo Two® that swings a single 20" diameter propeller. For the ultimate in power-handling, MerCruiser offers our X-Series Bravo drives including the offshore racer's choice – the Bravo One XR.

## BRAVO DRIVE FEATURES – A CLOSER LOOK.

### X-DRIVE FEATURES

Reinforced ribbed top cap and steel chimney reliably secure bearings under high load – X & XR

Heavy-duty Permalube U-joint to reliably transmit big engine torque and horsepower – X & XR

Net-forged steel bevel gears for highest strength and greatest durability – XR only

Heavy-duty caged needle bearing – XR only

Stronger drive shaft – XR only

Larger diameter propshaft – Bravo One XR only

### CORROSION PROTECTION

Ultrapure aluminum anodes provide enhanced protection versus traditional zincs

MerCruiser exclusive MerCathode active corrosion prevention system monitors the galvanic potential of the drive and condition of your anodes. It uses micro-voltage to electrically counteract corrosion, providing continuous cathodic protection (not shown).

Two anticavitation plate anodes for extra protection

MerCruiser-exclusive XK-360 low-copper, high-strength aluminum alloy is highly corrosion resistant

Tri-Paint system (Irridite, Electro-Deposition Primer and statically applied Powder Paint) creates a tough, durable corrosion-resistant barrier

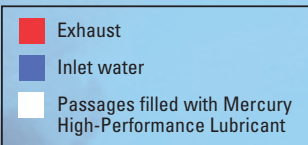
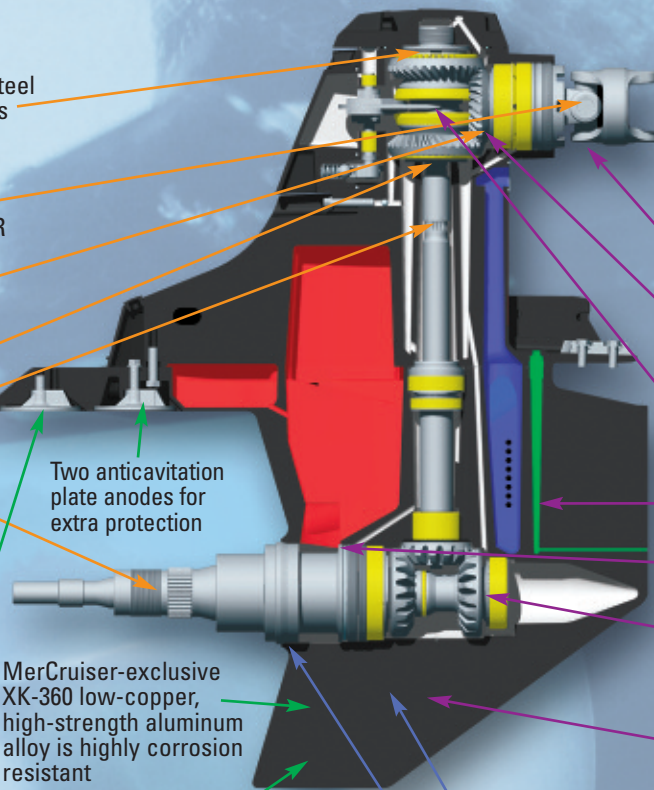

### STANDARD FEATURES

Permalube U-joint – No maintenance required

Near-net-forged helical steel gears for quiet operation and outstanding durability

High-strength, smooth-shifting cone clutch with F-N-R

Integrated speedometer pickup, digital output optional

Complete through-prop exhaust maximizes power and reduces noise levels

Forged steel bevel gears with twin counter-rotating propshafts – Bravo Three

Large rudder area for enhanced steering control

### SEACORE

Industrial hardcoat anodizing with four-year limited warranty against corrosion

Stainless steel package, including stainless bearing carrier

